

Трёхосный самосвал 6x4

NXG3250D5NC G5

NXG3250D5NC HANVAN G5 DUMP TRUCK TECHNICAL SPECIFICATION



UNIVERSAL MACHINERY LLC

XUZHOU XCMG E-Commerce Inc.

一、整车参数 Vehicle parameters

	整机型号/Vehicle Model	NXG3250D5NC		
设计质量参数 Mass parameter	整备质量/Curb weight	15500 kg		
	最大允许总质量//GVW	41500kg		
性能参数 Performances	最高车速/Max. Speed	78 km/h		
	最小转弯直径/ Min. turning diameter	18.6m		
	最大爬坡度/Grade ability	≥28%		
	最大驻坡度/Hill-hold ability	≥20%		
	油箱容积/Fuel Tank	300L		
尺寸参数 Dimensions	外形尺寸 Overall dimensions	长/Length	8480mm	
		宽/Width	2550mm	
		高/Height	3598mm	
		轴距/Wheelbase	3800+1400mm	
	轮距/Wheel tread	前轮/Front	2005mm	
		后轮/Rear	1860mm	
		最小离地间隙/Min. Clearance	260mm	
		接近角/Approach angle	25°	
		离去角/Departure angle	23°	
		前悬/Front suspension	1485mm	
	后悬/Rear suspension	1795mm		
驾驶室/Cab	型号/Model	G5LM		
	乘员人数/Passengers	2, 3		
发动机/Engine	型号/Model	D10.38-50		
	总排量/Displacement	9.726L		
	额定功率/Output power	276kW		
	最大扭矩/torque/speed	1560 N.m		
离合器/Clutch	型号/Model	Φ430 推式膜片弹簧离合器 Pull type diaphragm spring clutch		
	操纵方式/Operation	液压操纵气助力/Hydraulic manual		
变速器 /Transmission	型号/Model	10JSD160/12JSD160T		
	操纵方式/Operation	软操/Flexible shaft		
	前进档速比/Forward ratio	14.86/12.08/9.39/7.33/5.73/4.46/3.48/2.71/2.1/1.64/1.28/1		

	倒档速比/Reverse ratio	14.24、3.19	
驱动桥/Driven axle	型号/Model	16T MAN	
	主减速器速比/Ratio	5.262	
	制动器类型/Brake type	鼓式/Drum type	
	差速锁/Differential lock	轴间、轮间差速锁 Differential lock between axles and wheels	
前轴/Front axle	型号/Model	9.5T	
	制动器类型/Brake type	鼓式/Drum type	
车轮 Wheel	轮辋/Rim	8.50V-20	
	轮胎/Tire	12.00R20-18PR	
车架/Frame	型式/Type	等宽直通梁/Rectangular beam	
	主纵梁截面/Main beam	300×90×8mm	
	衬梁截面/Auxiliary beam	284×80×8mm	
	车架总成宽度 Width of chassis structure	865mm	
悬架 Suspension	前/Front	型式/Type	纵置多片簧/Multi-spring
		钢板弹簧片数 Amount of spring plate	10
	后/Rear	型式/Type	纵置多片簧/Multi-spring
		钢板弹簧片数 Amount of spring plate	13
转向系 Steering	转向器型式/Steering type	Φ120/循环球式液压助力 Circulating ball type hydraulic power	
	转向器速比/Ratio	23.27	
	转向油泵最大压力 Max pressure of pump	14Mpa	
制动系 Brake	额定工作压力/Rated working pressure	1Mpa	
	行车制动系型式/Driving brake	双回路气压制动 Dual circuit pneumatic braking	
	驻车制动系型式/Parking brake	弹簧储能断气制动 Spring energy storage air brake	
	辅助制动系型式/Assistant brake	发动机排气制动 Engine exhaust brake	
	电压/Voltage	24v	
	发电机功率/Generator power	1.96 kw	
	蓄电池电压/电容 Battery voltage and Capacitance	2×12V/165Ah	

二、车辆照片 Vehicle pictures

1. 三视图 View drawings

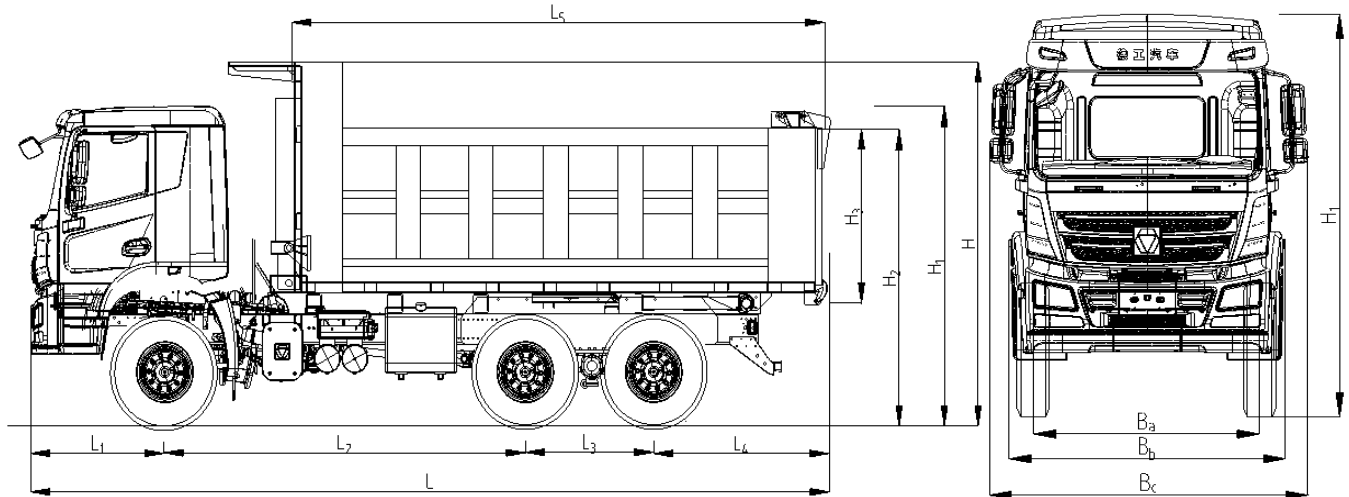

外形尺寸/Appearance size	
L1 前悬/Front overhang	1400mm
L2 第一、二轴轴距/First and second wheel base	3800mm
L3 第二、三轴轴距/Second and third wheel base	1350mm
L4 后悬/Rear overhang	1840mm
L5 货箱长度/ Container length	5600mm
L 最大长度/Max length	8400mm
H1 驾驶室高度/Cab height	3120mm
H2 货箱离地高度/ Height of container above ground	3070mm
H3 货箱高度/ Container height	1870mm
H 最大高度/Max height	3550mm
Ba 轮距/Wheel tread	2060mm
Bb 整车宽度/Overall width	2520mm
Bc 最大宽度/Max width	2900mm

2. 外观照片 Vehicle appearance



3.



ООО «Юниверсал Машинери»
г. Киев, Бульвар Верховного Совета, 7.
<https://www.xcmg-ukraine.com.ua>
моб. +38 050 447 93 93
моб. +38 067 457 00 44
e-mail: info@xcmg-ukraine.com.ua
<https://www.facebook.com/UAXCMG/>