

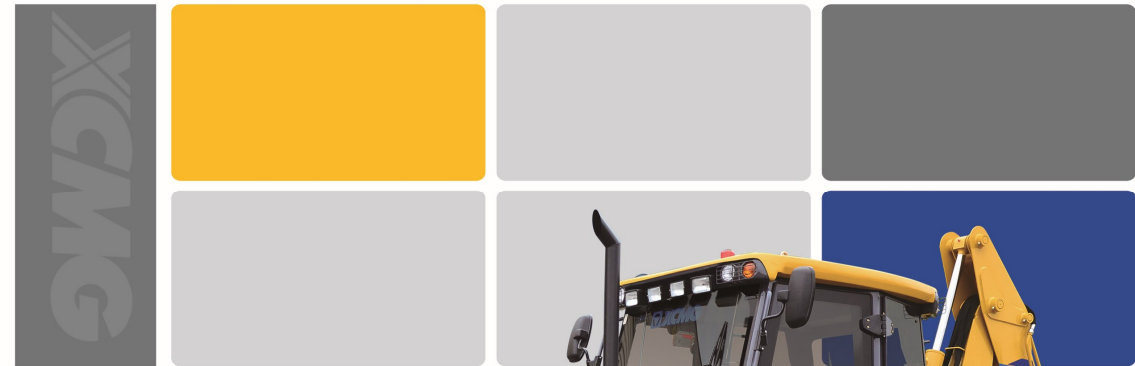

XCMG FOR YOUR SUCCESS

XC870K/XC870HK

Backhoe Loader



20170324



XC870K/XC870HK

Product Overview

- XC870K/XC870HK is a K series backhoe loader newly launched by XCMG. This product is upgraded on the basis of the mature equipment and technical performances of present products, including the upgrade of engine emission, lightweight upgrade of structural parts, and optimization of working device parameters, to further improve the comfort, safety, maintainability, reliability, supportability, and economy of the product.



Characteristics

Performance features

- The overall layout and the axle load distribution are more reasonable to achieve better traveling stability and the maximum traveling speed is up to 40km/h to realize faster site transfer speed.
- The domestic leading hydraulic system distribution technology features high energy-saving and efficiency. The maximum flow is 154L/min to meet the configuration demands of more attachments.
- It can be applied with diversified environment adaptability technologies, including the high temperature, low temperature, highland, and heavily dusty environments, upon the user's customization depending on own needs.
- The highest breakout force on the loading end is leading the industry by 15%~20% compared with like models. The advanced structure and hinge points on the digging end and the industry's largest rotating angle of the bucket ensure strong soil holding capacity.

Environmental-friendliness

- The double pump confluence system with unloading function can automatically or manually switch over the individual pump based on the working condition and unload the high pressure by auxiliary pump, featuring high intelligence and energy-saving.
- The XCMG's independently developed load-sensing system features smooth digging and loading combination motions, low motion changeover impact, and high efficiency and energy-saving.
- During the digging and loading combination operations, the engine power to the drive system can be easily cut off so that all power is supplied to the hydraulic system to improve the digging and loading efficiency.
- The machine automatically switches to two-wheel drive mode while traveling in gear IV to eliminate the parasitic power loss.

XC870K/XC870HK

High Strength and High efficiency for Extensive Adaptability

Digging End

- The high strength structural design features high operation efficiency, with the breakout force up to 63kN.
- The digging end can be equipped with the attachments, including breaking hammer, twist drill, vibrating tamper, hydraulic shear, and planer.

Loading End

- The design optimized and industry leading 8-link working device features good levelness of bucket and rapid operations.
- The ultra-high discharge height (2770mm) and ultra-high breakout force (66kN) lead the like products.

- The loading end can be equipped with four-in-one bucket, manhole cover planer, snow shovel, and forks.



- XC870K adopts middle wing-shaped outriggers, featuring beautiful appearance, high load-carrying capacity, and ultra-high stability.
- XC870HK adopts lateral H-shaped outriggers so that, while guaranteeing the operation stability, the digging device features lateral movement function and more extensive digging scope.



Operation Safety and Control Comfort

- The 360° panoramic view luxury cab with air conditioning system features large space, good sound and heat insulation, and good shock absorption. With openable side windows and rear window, the cab realizes broader visual field and comfortable operations.
- The suspension seats equipped are multi-angle adjustable. The joysticks and the instrument panel are arranged in accordance with ergonomic principles to realize comfortable operations.
- The radio/audio player, storages, cup holders, and cigarette lighter are equipped to sufficiently embody the humanized design philosophy.
- The gearshift lever is equipped with power cutoff switch to ensure simple switchover between high and low gears.
- The FOPS&ROPS cab and the fire extinguisher and safety hammer equipped guarantee the personal safety of the operator.



- The operating status alarms equipped realize real-time monitoring and guarantees operation safety.



- The maintenance-free wet-type brake axle features one-sided braking function and low turning radius.

XC870K/XC870HK

High-End Configuration for High Firmness and Reliability

- The world's renowned brand engine equipped features strong power and reliable quality.
- The CARRARO special transmission and drive axle for backhoe loader and the high speed intelligent axle disengagement mechanism drive technology are equipped to realize stable and reliable drive.
- The first-class quality hydraulic units equipped ensure the working safety and reliability.
- The electronic control combination joysticks from world's renowned brand feature high reliability and simple operations.
- The frame and the working device are optimized through finite element analysis to realize reasonable stress distribution and firm structure.

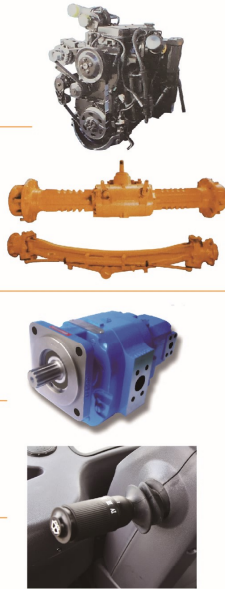

Convenient Maintenances

- The XCMG's pioneering split engine hoods can open forward for a large angle to ease the disassembly and installation of two engine hoods and help the maintenances.
- The central pressure measurement port is configured to ease the daily inspection.
- The lubricating points for various hinge joints are concentrated to realize easy and fast maintenances.



Outline Dimensions

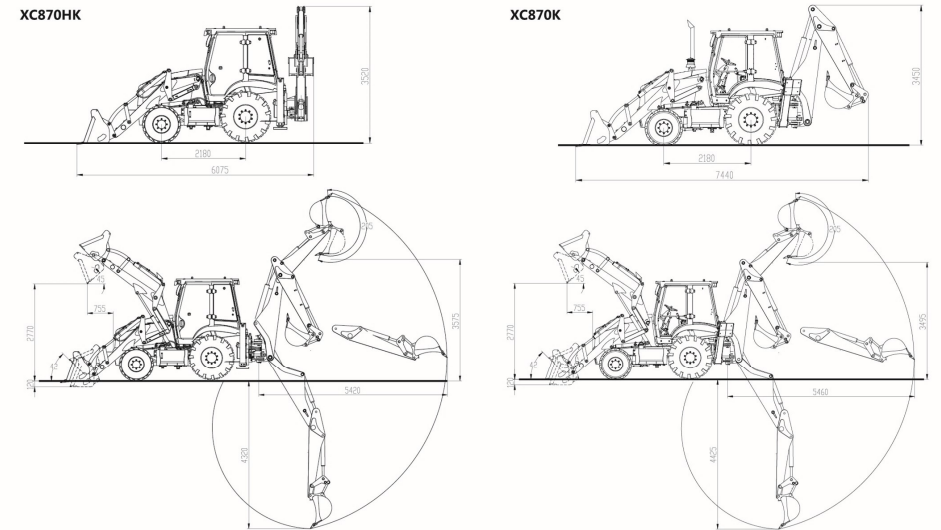

MAIN SPECIFICATIONS

Items	Model								Unit	
	XC870K				XC870HK					
Chassis type	integrated									
Drive style	4 drive/2 drive									
Digging working device	middle				side					
Outline dimensions (L×W×H)	7440×2350×3450				6075×2350×3520				mm	
Total weight	7600								kg	
Max. travel speed	≥40								km/h	
Wheelbase	2180								mm	
Engine	Power	82(Cummins)	74(Cummins)	74.9(Deutz dalian)	70(weichai)	82(Cummins)	74(Cummins)	74.9(Deutz dalian)	70(weichai)	kW
	Supplier	tier 3	tier 2	tier 3	tier 2	tier 3	tier 2	tier 3	tier 2	
Loading device	Bucket capacity	1.0				1.0				m³
	Rated load	2500								kg
	Max. breakout	66								kN
	Max. discharge height	2770								mm
	Max. discharge distance	755								mm
Digging device	System pressure	24								Mpa
	Bucket capacity	0.3				0.25				m³
	Max. digging radius	5460								mm
	Max. digging depth	4425								mm
	Max. digging force	63								kN
System pressure	24								Mpa	

Structure and specification are subject to change without notice. In case there is any difference between the description of the machine and the substantial machine, the substantial machine should govern.